

Foratrice a due mandrini manuale
per fascioni e zoccoli



Manual double-spindle drilling
machine for cross-pieces and bases



Perceuse manuelle à deux broches
pour poutre et plinthe



Taladradora de dos portabrocas ma-
nual para faja media y del zócalo



Mod. FMZ/S



Mod. FMZ/SP



Mod. FMZ/PS

DESCRIZIONE

Foratrice manuale a due mandrini per forature multiple su montanti di profili in alluminio per accoppiamenti a 90° del fascione e dello zoccolo.

SPECIFICHE TECNICHE

- Mod. FMZ/S

Discesa testa manuale
Traslazione punte manuale
Morsa manuale
Battuta stellare a sei posizioni per centraggio morse

- Mod. FMZ/SP

Discesa testa manuale
Traslazione punte manuale
Morsa pneumatica
Battuta stellare a sei posizioni per centraggio morse

- Mod. FMZ/PS

Discesa testa manuale
Traslazione punte pneumatica
Morsa pneumatica
Battuta stellare a sei posizioni per centraggio morse

DOTAZIONI

Punte Øi 6,5mm Øe 12mm
Schermo antitrucciolo
Tanica lubrificazione
Manuale di servizio
Chiavi di servizio

OPTIONAL

Punte Øi 6,5mm Øe 14mm

DESCRIPTION

Manual double-spindle drilling machine for multiple uprights drilling on aluminium and iron sections, for 90° joining of cross-piece and base.

TECHNICAL DATA

- Mod. FMZ/S

Manual lowering head
Manual traslation bits
Manual vices
Stellar stop-shoulder 6 position for centering vices

- Mod. FMZ/SP

Manual lowering head
Manual traslation bits
Pneumatic vices
Stellar stop-shoulder 6 positions for centering vicesx

- Mod. FMZ/PS

Manual lowering head
Pneumatic traslation bits
Pneumatic vices
Stellar stop-shoulder 6 positions for centering vicesx

DOTAZIONI

Bits Øi 6,5mm Øe 12mm
Protective carter
Lubrification bottle
Instruction manual
Set of spanners

OPTIONAL

Øi 6,5mm Øe 14mm bits

DESCRIPTION

Perceuse manuelle à deux broches pour des percages multiples sur le montant des profils en aluminium et pour l'application à 90° de la poutre et de la plinthe.

DONNEES TECHNIQUES

- Mod. FMZ/S

Descente tete manuelle
Trasl. meche manuelle
Etaux manuelle
Butée rotative 6 position pour le centrage du profilè

- Mod. FMZ/SP

Descente tete manuelle
Trasl. meche manuelle
Etaux pneumatique
Butée rotative 6 position pour le centrage du profilè

- Mod. FMZ/PS

Descente tete manuelle
Trasl. mèche pneumatique
Etaux pneumatique
Butée rotative 6 position pour le centrage du profilè

EQUIPEMENT

Mèche Øi 6,5mm Øe 12mm
Protection zone de coupe
Bouteille lubrification
Manuel d'istruction
Clès de service

OPTIONAL

Mèche Øi 6,5mm Øe 14mm

DESCRIPCION

Taladradora manual de dos portabrocas, para taladros multiples de perfiles en aluminio, para acoplamiento a 90° de la faja media y del zócalo.

DATOS TECNICOS

- Mod. FMZ/S

Descensa cabeza manual
Trasl.brocas manual
Morsas manual
Topes estelar en 6 posiciones por centrado morsas

- Mod. FMZ/SP

Descensa cabeza manual
Trasl.brocas manual
Morsas neumatica
Topes estelar en 6 posiciones por centrado morsas

- Mod. FMZ/PS

Descensa cabeza manual
Trasl.brocas neumatica
Morsas neumatica
Topes estelar en 6 posiciones por centrado morsas

EQUIPAMIENTOS

Brocas Øi 6,5mm Øe 12mm
Carter de seguridad
Botella de lubrificación
Manual de servicio
Llaves de servicio

OPTIONAL

Brocas Øi 6,5mm Øe 14mm

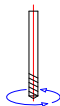
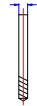
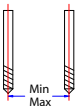
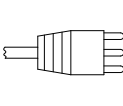
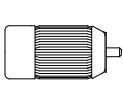
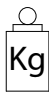
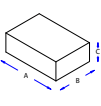

Dati Tecnici- Technical characteristics- Donnees techniques- Datos Tecnicos

TYPE							
FMZ/S FMZ/SP FMZ/PS	2800 g/	D=12/6.5mm	Min=26mm Max=180mm	220-380V 50Hz	0.75 Hp 0.35 Kw 2800 g/	100	A=1500mm B=560mm C=1350mm

