

FL-3M Faces

This machine should be used for applying and cutting the plastic material protection (film) in **3 flat faces** of the profiles. Ideal guide profile.

Dual drive system for a low-speed input.

Complies with CE safety and manufacturing of machinery (2006/42/EC).

The machine uses rollers as film applicator that is rotated by a motor and automatically cuts the film electrical resistance. This adequately protected.

The positioning and cutting of the film is done automatically, a sensor detects the onset of the profile, allowing the machine is then complete the process of placement.

The machine body is resistant ensuring their accuracy.

The high quality of this machine and its ease of operation makes it suitable for use by operators.



ESB-64058050 C/ Puigbarral, 44 Nau 4F Pol.
Ind. Can Petit 08227 TERRASSA, BARCELONA
(SPAIN)

Tel: (+34) 93 789 29 93
Mail: export@rpaluminium.com
admin@rpaluminium.com

 **rp**[®]
aluminium machinery

FL-3M Faces

FL Family

FL-3M Faces

FL-3M Faces



Technical Data

Maximum length profile	Unlimited
Height max. profile	250 mm.
Width max. profile	100 mm.
Height max.	250 mm.
Width film coil	100 mm.
Thick film coil	35 a 100 microns
Outside □ film coil	300 mm.
Motor	0 / 5 CV
Working pressure	1-6 kg.
Working height	940 mm



Overall Dimensions

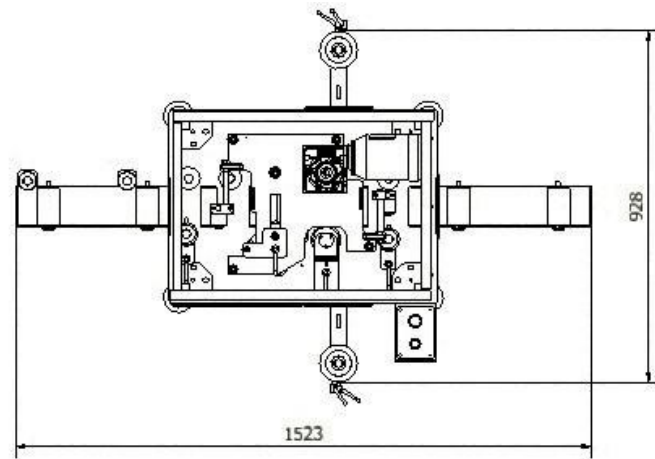
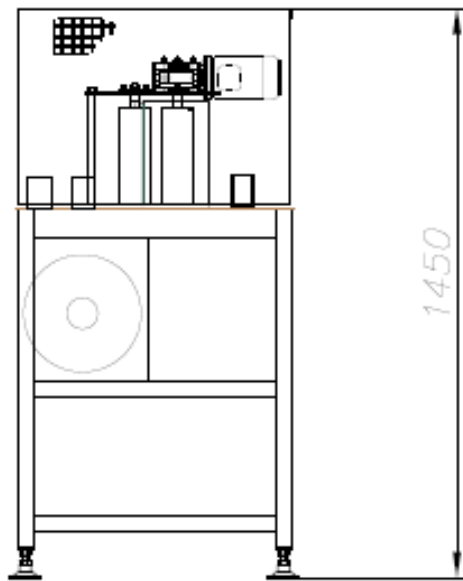

ADDITIONAL MATERIAL

Functions keys.
Installation, use and maintenance.

OPTIONAL MATERIAL

Roller bench entry and exit 3,9 m. Ref.: BR-1
Roller bench entry and exit 1,85 m. Ref.: BR-2
Downloader profiles. Ref.: DES-2

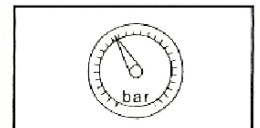
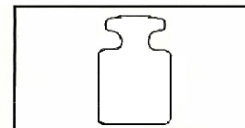

Mono 220v 1Kw –
230V –50/60 HZ

160 kg.

6 +7 bar

